

D8: G? 4 D 6 <FK 6 BGA6 <? @88 F<A:

E8 CF8 @5 8 D) - \$*((1

/ 2 (C&@ &

A Regular Meeting of the Terrell City Council was held on Tuesday, September 15, 2009 at 7:00 p.m. in the City Council Chambers located at 201 East Nash Street, Terrell, Texas with the following members present:

**6 BGA6 <? @8 @5 8 D !) ; 4 ? D < 6 ; 4 D 7 E
6 BGA6 <? @8 @5 8 D ! * E4 A7 D4 I <? EBA
6 BGA6 <? @8 @5 8 D ! + D < 6 > K =BD7 4 A
6 BGA6 <? @8 @5 8 D ! , =4 6 > =BA8 E
6 BGA6 <? @8 @5 8 D ! - 7 B A F ; GD@4 A**

) & 6 NYa \ _QR &

Mayor Hal Richards called the meeting to order.

*** & < [c \ PNaV [&**

Councilmember Jack Jones gave the opening prayer.

**, & 7 VPb `` N Q6 \ [`QR 4]] \ cNY \ SE] RPWY6 Wf 6 \ b [PY @ RRaV TI \ _X U] @ V baR
\ S 4 bTb `a * / \$ *((1 N Q DRibY_ 6 Wf 6 \ b [PY @ RRaV T @ V baR \ S ER] aRZ OR) \$
*((1 &**

Mayor Pro tem Don Thurman made a motion to approve Special City Council Meeting Workshop Minutes of August 27, 2009 and Regular City Council Meeting Minutes of September 1, 2009. The motion was seconded by Councilmember Sandra Wilson. Ayes all; Nays none. Motion carried.

+ & C_RR aNaV [\ SC \ PNZ NaV [&

Mayor Hal Richards presented a Proclamation for the month of September 2009 as Adult Education Month .

Mayor Hal Richards recognized students from Trinity Valley Community College attending the Council Meeting.

- & ; RN_DRZNX S \ Z HVa _ ` &

None were made.

A8I 5 GE<A8 EE

. & 7 VPb `` N Q6 \ [`QR 4]] \ cNY \ S6 N_WYRef [FRP&

Danny Booth representing Terrell Economic Development Corporation presented to Council for discussion and consideration Carlisle SynTec. Councilmember Jack Jones made a motion to consider Carlisle SynTec Agreement with Terrell Economic Development Corporation complete. The motion was seconded by Councilmember Sandra Wilson. Ayes all; Nays none. Motion carried.

**/ & 7 VPb `` N Q6 \ [`QR 4]] \ cNY \ SDRPNZ V T 9 Y \ Q CNY C _] R.f V @ Ra \ P_Ra
5 b ` V R ` CN_X&**

Danny Booth representing Terrell Economic Development Corporation presented to Council for discussion and consideration Reclaiming Flood Plan Property in Metrocrest Business Park. Mayor Pro tem Don Thurman made a motion to approve Reclaiming Flood Plain Property in Metrocrest Business Park not to exceed \$30,000. The motion was seconded by Deputy Mayor Pro tem Ricky Jordan. Ayes all; Nays none. Motion carried.

0& 7 VBb`` N Q 6 \ [` QR 4]] \ cNY \ S FR_RY 8 P [\ Z P 7 R RY] Z R a 6 \ _] \ _ NaV [5 f Yd ` 4 Z R QZ R a&

Danny Booth representing Terrell Economic Development Corporation presented to Council for discussion and consideration Terrell Economic Development Corporation Bylaws Amendment. Deputy Mayor Pro tem Ricky Jordan made a motion to approve Terrell Economic Development Corporation Bylaws Amendment. The motion was seconded by Councilmember Sandra Wilson. Ayes all; Nays none. Motion carried.

1& 7 VBb`` N Q 6 \ [` QR 4]] \ cNY \ S ; \ aRY @ \ aRY FN e 9 b [QDR ` b R a ` S _ * ((1 %) (&

Dan Sowers 112 E. Moore presented to council a proposal for Hotel/Motel Tax Funds.



September 15, 2009

Proposed HOT Funds:

Downtown Monument Sign

- **Center Median at Rockwall and West Moore Ave.**
 - Approx. 12' wide (not inc. curb)
 - Approx. 10' in front of first Planter
- **4'x5' Monument Sign**
 - Constructed of HDU (faux brick and mortar)
 - Double-Sided
- **West Side of Sign:**
 - Welcome to Historic Downtown Terrell
 - Est. 1873
- **East Side of Sign:**
 - Historic Downtown Terrell
 - Est. 1873
 - Stop, Shop, Enjoy!

Total Cost: \$5,000 to \$7,000

- Actual cost TBD upon choice of signage shape, lettering, size and materials.

We have concluded, after measuring, driving and photographing the best location for the proposed second monument sign, that there is not a site on the East side of town that is substantial enough to support another sign.

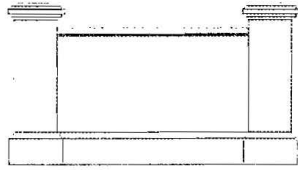

Monument Model 02
Size: (5') x (9') x (21")

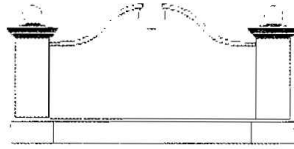

Monument Model 03
Size: (5' 6") x (11') x (16")

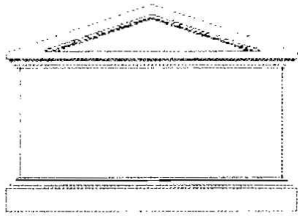

Monument Model 05
Size: (7'3") x (10') x (20")

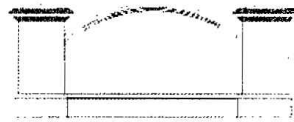

Monument Model 10
Size: (5') x (12') x (24")

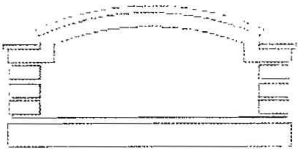

Monument Model 11
Size: (5') x (10') x (16")

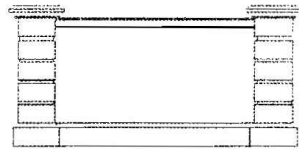

Monument Model 13
Size: (5') x (10') x (16")

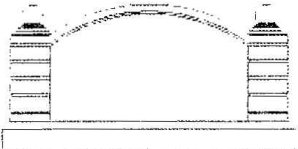

Monument Model 22
Size: (5') x (10') x (16")

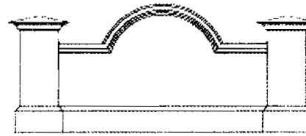

Monument Model 25
Size: (5') x (11'10") x (28")

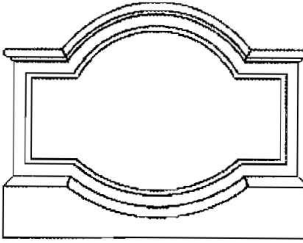
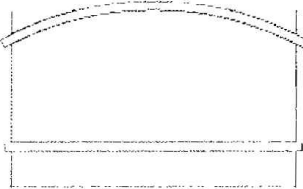
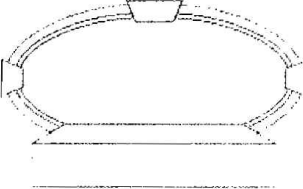
 <p>Monument Model 26 Size: (5'7.5") x (13'6") x (21")</p>	 <p>Monument Model 27 Size: (5' 7.5") x (7' 3") x (21")</p>
 <p>Monument Model 36 Size: (5'3") x (8'7") x (12")</p>	 <p>Monument Model 38 Size: (5') x (8'2") x (12")</p>
<p>Monument signs are the right choice for attracting the attention you deserve. Spring Valley Signs provides you with attractive and durable monument signs, carefully designed to meet your specifications, made out of superior materials, and constructed to outlast conventional signs. Our designers will work with you to select the best choice of monument style. The <u>forty standard monument styles</u> encourage creative ideas, and our designers help you visualize a distinctive monument sign for your business.</p> <p>The custom made carved sign on the monument is hand crafted and has the feel of an individual work of art. Each of these Spring Valley Signs is carved out of High Density Urethane (HDU). The base material of your monument sign is made from rugged Hybrid Plastic Polymer, with a protective shell that has superior impact resistance and weathering durability. The surface is fade resistant, and weather and insect proof. Your monument design may include columns and caps, pole covers, and architectural trim.</p> <p>Your monument sign design is extremely versatile, with many options available. You can design into your monument sign 3-dimensional graphics, multiple panels, and illumination. Monuments come in a wide selection of colors, textures, and accents. Faux brick accents, stone veneer, stucco, and the real 'laid stone' look, are just some of the options. <u>Take a look at all our monument styles.</u></p> <p>Installation of these monument signs is easy since they are prefabricated. There is no site mess or installation delay due to the weather!</p> <p>Monument signs are the choice of the future. You may be starting a business, creating a new image for your establishment, or embellishing your existing signage; whatever you need, Spring Valley Signs can design and create other indoor and outdoor signs that match the style of your monument sign. <u>Contact us for a free consultation</u> and soon a new monument sign will be at the entrance of your business.</p>	

John Rounsavall, City Secretary/Finance Director presented to Council for discussion and consideration Hotel/Motel Tax Fund Requests for 2009-2010. Councilmember Jack Jones made a motion to approve recommended allocations for Hotel/Motel Tax Fund Requests for 2009-2010. The motion was seconded by Deputy Mayor Pro tem Ricky Jordan. Ayes all; Nays none. Motion carried.

**2009-2010
 Allocation**

Kaufman County Civic Theatre	12,000
No. 1 British Flying Training School Museum	14,500
Terrell Alliance for Education & the Arts	14,600
Terrell Chamber of Commerce Convention Center	166,800
Terrell Heritage Society	18,800
Terrell ISD Performing Arts Center	14,500
Lake Country Productions	11,900
Terrell Downtown Association	2,600
North East Texas Fine Art Alliance	1,000
Carnegie Museum	30,000
	286,935

)(& 7 VPb`` N Q 6 \ [`VR 4]] \ cNY \ S N DR \ Z Z R Q N \ [DRIN_QV T 4]] \ cNY \ S 4 YR \ N \ VR 8 eaR_V_ @ N \ R_WY] R ERPaV \ + / & \ S aUR L \ [VT B_QV N PR \ [C \] R af 7 RP_VORQ N ? \ a) \$ F_N 4 QQ \ [\$ 6 W \ S FR_RR > NbSZ N 6 \ b \ af \$ FR N 'L6 %1%, #&

Terry Capehart, Director of Municipal Development and Jerry Defeo representing Master Auto Body of Mesquite presented to Council for discussion and consideration Alternative Exterior Materials per Section 37.4 of the Zoning Ordinance on Property Described as Lot 1, Tran Addition, City of Terrell, Kaufman County, Texas (ZC-09-04). Mayor Pro tem Don Thurman made a motion to approve Alternative Exterior Materials per Section 37.4 of the Zoning Ordinance on Property Described as Lot 1, Tran Addition, City of Terrell, Kaufman County, Texas (ZC-09-04). The motion was seconded by Councilmember Jack Jones. Ayes all; Nays none. Motion carried.

)) & DRPREREaSSG] QNRDRIN_QV T 9 Y % 8 cR a&

Lynnette Nadeau, Marketing Director presented to Council for discussion Staff Update Regarding Fly-In Event. There was no action taken on this item.

)* & 7 VPb`` N Q 6 \ [`VR 4]] \ cNY \ S B_QV N PR A \ %*, +(%9VR N Q C \ YR 6 N `WV N \ [&

Carol Holland, Director of Human Resources, Police Chief Jody Lay and Fire Chief Jim Harper presented to Council for discussion and consideration Ordinance No. 2430 Fire and Police Classification. Councilmember Sandra Wilson made a motion to approve Ordinance No. 2430 Fire and Police Classification on first reading. The motion was seconded by Councilmember Jack Jones. Ayes all; Nays none. Motion carried.

ORDINANCE NO. 2430

AN ORDINANCE OF THE CITY COUNCIL OF THE CITY OF TERRELL AMENDING CHAPTER 9, SECTION 9-9. CIVIL SERVICE CLASSIFICATION PLAN; (a) CLASSIFICATION OF FIRE FIGHTERS AND (b) CLASSIFICATION OF POLICE OFFICERS, (1) POSITIONS APPOINTED BY THE CHIEF OF POLICE AND FIRE CHIEF; (2) POLICE OFFICER CLASSIFICATION; OF THE CITY CODE OF ORDINANCES OF THE CITY OF TERRELL, TEXAS; PROVIDING FOR REPEAL OF CONFLICTING ORDINANCES; PROVIDING FOR SEVERABILITY; AND PROVIDING AN EFFECTIVE DATE.

)+ & 7 VPb`` N Q 6 \ [`VR 4]] \ cNY \ S B_QV N PR A \ &*, +) %C \ cVQV TS _ aUR @ \ [aUY 6 \ YR PaV \ N QDR \ _aV T \ S; \ aR B P P b] N H F N e &

John Rounsavall, City Secretary/Finance Director presented to Council for discussion and consideration Ordinance No. 2431 Providing for the Monthly Collection and Reporting of Hotel Occupancy Tax. Councilmember Sandra Wilson made a motion to approve Ordinance No. 2431 Providing for the Monthly Collection and Reporting of Hotel Occupancy Tax on first reading. The motion was seconded by Mayor Pro tem Don Thurman. Ayes all; Nays none. Motion carried.

ORDINANCE NO. 2431

AN ORDINANCE OF THE CITY OF TERRELL, KAUFMAN COUNTY, TEXAS AMENDING ORDINANCE NUMBER 2099; PROVIDING FOR THE MONTHLY COLLECTION AND REPORTING OF A HOTEL OCCUPANCY TAX; PROVIDING A PENALTY FOR THE FAILURE TO REPORT OR COLLECT THE TAX; PROVIDING CERTAIN DEFINITIONS PROVIDING FOR CERTAIN EXEMPTIONS; PROVIDING FOR THE CITY COUNCIL TO ENACT A BUDGET FOR EXPENDITURES OF FEES COLLECTED THROUGH THE HOTEL OCCUPANCY TAX; PROVIDING FOR REPEAL OF CONFLICTING ORDINANCES; PROVIDING FOR SEVERABILITY; AND PROVIDING AN EFFECTIVE DATE:

), & 7 VPb`` N Q 6 \ [`VR 4]] \ V aZ R a` a FR_RY @ b [VY NY 4 V] \ _a5 \ N Q &

Torry Edwards, City Manager presented to Council for discussion and consideration Appointments to Terrell Municipal Airport Board. Deputy Mayor Pro tem Ricky Jordan made a

motion to re-appoint Jerry Gibson and Terry Eason to the Terrell Municipal Airport Board. The motion was seconded by Councilmember Sandra Wilson. Ayes all; Naves none. Motion carried.

) - & 7 VPb` N Q6 \ [`VR 4]] \ V aZ R a` a FR_RYCN_X5 \ N_Q&

Mayor Pro tem Don Thurman made a motion to re-appoint Dale Martin and Sandra Harrelson to the Terrell Park Board. The motion was seconded by Councilmember Jack Jones. Ayes all; Naves none. This item to be placed on the next meeting agenda for the appointment to replace Robert Lee.

). & 7 VPb` N Q6 \ [`VR 4]] \ V aZ R a` a FR_RYCN [VTN QL \ [VT6 \ ZZ V V [&

Councilmember Jack Jones made a motion to appoint Joe Hood to replace Don Archer and re-appoint Tom Aldinger to the Terrell Planning and Zoning Commission. The motion was seconded by Councilmember Sandra Wilson. Ayes all; Naves none. Motion carried.

) / & 7 VPb` N Q6 \ [`VR 4]] \ V aZ R a a K \ baU4 Qc V \ _ f 6 \ ZZ V V [&

Lynnette Nadeau, Marketing Director presented to Council for discussion and consideration Appointment to Youth Advisory Commission. Councilmember Sandra Wilson made a motion to appoint Marian Carver to the Youth Advisory Commission. The motion was seconded by Mayor Pro tem Don Thurman. Ayes all; Naves none. Motion carried.

6 BAE8 AF 4 : 8 A7 4

Councilmember Jack Jones made a motion to adopt Ordinance No. 2427, Ordinance No. 2428 and Ordinance No. 2429 on second reading on CONSENT AGENDA. The motion was seconded by Councilmember Ricky Jordan. Ayes all; Naves none. Motion carried.

) 0 & 7 VPb` N Q 6 \ [`VR 4 Q] aV [\ [ER [Q DRNQ T \ S B_QV N PR A \ & *, */ g 4 Q] aVT aUR9 VPNYKRN_ * ((1%)(5 bQIR&

ORDINANCE NO. 2427

4 A BD7 <A4 A68 B9 F; 8 6 <FK B9 F8DD8?? \$F8J4E 4 CCDBH<A:
4 A7 47 BCF<A: 4 5 G7: 8F 9BD F; 8 9 <E64? K84D 58: <AA<A:
B6FB58D)\$*((1\$4A7 8A7<A: E8CF8 @58D +(\$*())(3 CDBH<7 <A:
F; 4 F 8J C8A7 <FGD8E9BD E4 <7 9 <E64? K84D E; 4 ?? 58 @478 <A
466BD74A68 I <F; E4 <7 5 G7: 8F3 4 CCDB CD<4 F<A: 4 A7
E8FF<A: 4 E<7 8 F; 8 A868EE4DK 9GA7E BGF B9 F; 8 : 8A8D4?
4 A7 BF; 8D D8H8AG8E 9BD E4 <7 9 <E64? K84D 9BD F; 8
@4 <AF8A4A68 4 A7 BC8D4F<BA B9 F; 8 H4D<BGE
78C4DF@8AFE 4 A7 9BD H4D<BGE 46F<H<F<8E 4 A7
<@CDBH8 @8AFE B9 F; 8 6 <FK3 CDBH<7 <A: 4 D8C84? <A:
6?4GE83CDBH<7 <A: 4 E8H8D45 <? <FK 6?4GE834A7 CDBH<7 <A:
4 A 89986 F<H8 74F8 &

I ; 8D84E\$ as required by Article V. of the City Charter, the City Manager has prepared and submitted to the City Council a proposed budget of revenues and expenditures for conducting the affairs of the City and providing a complete financial plan for the fiscal year beginning October 1, 2009 and ending September 30, 2010; and

I ; 8D84E\$ the City Council has received the City Manager s proposed budget, a copy of which and all supporting schedules have been filed with the City Secretary of the City of Terrell, Texas; and

I ; 8D84E\$ the City Council has conducted the necessary public hearings as required by law;

NOW THEREFORE BE IT ORDAINED BY THE CITY COUNCIL OF THE CITY OF
TERRELL, TEXAS:

ES 6 F<BA) &That the proposed budget of the revenue and expenditures necessary for conducting the affairs of the City of Terrell, Texas, is as follows:

	REVENUES	EXPENDITURES
General Fund	\$16,532,767	\$15,726,874
Utility Fund	\$12,288,044	\$ 9,612,118
Equipment Replacement Fund	\$ 1,205,703	\$ 845,068
Airport Fund	\$ 2,745,961	\$ 1,500,137
Tourism Fund	\$ 333,769	\$ 0
Capital Improvement Fund	\$ 663,067	\$ - 170,000
Utility Capital Reserve Fund	\$ 2,395,940	\$ 1,010,000
Impact Fees Fund	\$ 832,753	\$ 419,000
Interest & Sinking No. 1 Debt Service Fund	\$ 2,760,224	\$ 2,519,482
Interest & Sinking No. 2 Debt Service Fund	\$ 298,976	\$ 119,400

and provides a complete financial plan for the fiscal year beginning October 1, 2009 and ending September 30, 2010 as submitted to the City Council by the City Manager, attached hereto as Exhibit A , and the same is hereby adopted and approved as the budget of the City of Terrell, Texas for the fiscal year beginning October 1, 2009 and ending September 30, 2010.

ES 6 F<BA * &That the sum of \$31,919,079 is hereby appropriated for the payment of the expenditures established in the approved budget for the fiscal year beginning October 1, 2009 and ending September 30, 2010.

ES 6 F<BA + &That the expenditures during the fiscal year beginning October 1, 2009 and ending September 30, 2010 shall be made in accordance with the budget approved by this ordinance unless otherwise authorized by a duly enacted ordinance of the City of Terrell, Texas.

ES 6 F<BA , &That all budget amendments and transfers of budgeted appropriations from one account to another account within any classification for the fiscal year 2008-2009 are hereby ratified and the budget Ordinance for fiscal year 2008-2009 heretofore enacted by the City Council be and the same is hereby amended to the extent of such transfers and amendments for all purposes.

ES 6 F<BA - &That specific authority is given to the City Manager to make the following adjustments:

1. Transfer of appropriations budgeted from one account classification to another account classification within the same department.
2. Transfer of appropriations from designated appropriation from one department or activity to another department or activity within the same fund.

ES 6 F<BA . &That all provisions of the Ordinances of the City of Terrell, Texas in conflict with the provisions of this ordinance be and the same are hereby repealed and all other provisions of the Ordinances of the City of Terrell, Texas not in conflict with the provisions of this Ordinance shall remain in full force and effect.

ES 6 F<BA / &That should any word, sentence, paragraph, subdivision, clause, phrase or section of this Ordinance be adjudged or held to be unconstitutional, illegal, or invalid, the same shall not affect the validity of this Ordinance as a whole, or any part or provision thereof other than the part so decided to be invalid, illegal or unconstitutional.

ES 6 F<BA 0 &This Ordinance shall take effect from and after its passage as the law and charter in such cases provide.

PASSED AND APPROVED THIS THE 1ST DAY OF SEPTEMBER, 2009.
 PASSED AND ADOPTED THIS THE 15TH DAY OF SEPTEMBER, 2009.

)1& 7 VB` ` N Q6 \ [` QR 4 Q] aV [\ [ER [QDRNQYT \ SB_QV N PRA \ &*, *0 g ERaYT
 aURFNe DNRS_ *((1&

ORDINANCE NO. 2428

AN ORDINANCE OF THE CITY OF TERRELL, TEXAS, FIXING THE TAX RATE OF ALL TAXABLE PROPERTY WITHIN THE CITY OF TERRELL, TEXAS, FOR THE YEAR 2009 AND LEVYING AND ORDERING COLLECTION FOR THE YEAR 2009 AND PROVIDING TO SECURE THE PAYMENT OF TAXES ASSESSED.

BE IT ORDAINED BY THE CITY COUNCIL OF THE CITY OF TERRELL, TEXAS:
SECTION I.

That there be and is hereby levied and ordered collected on each One Hundred Dollar (\$100.00) valuation of all taxable property, both real and personal, and all property of every kind and description subject to taxation within the corporate limits of the City of Terrell, Texas, on January 1, 2009, the sum of \$0.65 based on 100% of the assessed valuation. Said rate of ad valorem tax is levied for the following purposes and the following amounts:

General Fund \$0.4637
Interest/Sinking Fund \$0.1819

SECTION II.

That all taxes collected by the city and districts for which it is collecting taxes, shall be payable on October 1, and if such taxes are not paid in full on or before January 31, of the succeeding year, the following penalties shall be payable: During the month of February, Six (6%) percent of amount of tax, plus 1% for each additional month delinquent, to a maximum of 12% beginning July 1. All delinquent taxes shall bear interest at the rate of one (1%) for each month or portion of month the tax remains delinquent.

SECTION III.

There is hereby on each and every item of taxable property a lien for the purpose of securing the certain payment of taxes assessed against said item of property, and said lien shall continue to exist against any item of property against which a tax is assessed hereunder until such tax, together with all interest, shall be paid.

SECTION IV.

That there be and there is hereby levied and ordered collected an annual occupation tax of fifty (50%) percent of the State occupation tax on each and every occupation subject to an occupation tax under the laws of the State of Texas.

SECTION V.

That this ordinance shall take effect and be in force from and after its passage and adoption.

PASSED AND APPROVED THIS THE 1ST DAY OF SEPTEMBER, 2009.

PASSED AND ADOPTED THIS THE 15TH DAY OF SEPTEMBER, 2009.

*(& 7 VPb`` N Q 6\[\`QR 4 Q]aV[\[ER[Q DRQYT \S B_QVN PR *,*1 %
4 ON Q [VTNC]_aV[\SaURG[QR:RY] RQ; RR Ea_RR DVUa%S% N N Q7 RRQYT
ENQDVUa%SI N a aUR; RR Ea_RR; \Z R d[R` 4``\PWaV[S_aURCb_] \`R\SN
C_VNREUN_RQ4 PPR``GaWf 8 NRZ R a&

ORDINANCE NO. 2429

AN ORDINANCE OF THE CITY OF TERRELL, TEXAS VACATING AND ABANDONING A PORTION OF THE HELEN STREET RIGHT-OF-WAY LOCATED IN BLOCK NO. 237, L. INGLEHART ADDITION, CITY OF TERRELL, KAUFMAN COUNTY, TEXAS

WHEREAS the property owner has requested that a portion of the Helen Street Right-of-Way in Block 237, L. Inglehart Addition of the City of Terrell, Kaufman County, Texas be vacated and abandoned; and

WHEREAS Helen Street right-of-way is only thirty (30) feet wide a width standards for a public street and has never been developed or

WHEREAS remaining portion of the Helen Street right-of-way that is utilized for a drainage easement for storm water management and transportation facility; and

WHEREAS appears that there is no present or foreseeable transportation right-of-way and no public purpose for which said right-of-way is needed

NOW, THEREFORE, BE IT ORDAINED BY THE CITY COUNCIL OF TERRELL, TEXAS:

ARTICLE I.

That any interest the City of Terrell might claim, now or in the future, in property be vacated and abandoned, as more particularly described in Exhibit A.

SECTION 1.

That said right-of-way, as set forth above, save any exception noted, is hereby vacated and abandoned, and every claim, right or rights, either the City of Terrell or the public generally has in and to said right-of-way is hereby released and relinquished forever; and whatever control, jurisdiction or dominion the City of Terrell has or may have had, either for itself or on behalf of the public generally, over the same as public right-of-way is hereby abandoned so that the City of Terrell neither for itself, nor on behalf of the public generally, shall hereafter have or assert any claim or right whatsoever to the same or any part thereof.

SECTION 2.

That this ordinance shall be filed of record in the Real Property Records of Kaufman County; and

That the Mayor is hereby authorized to execute a Special Warranty Deed on behalf of the City of Terrell to interests in any of the above described right-of-way upon the request of the property owner.

PASSED AND APPROVED on first reading this the 1st day of September, 2009.

PASSED AND ADOPTED on second reading this the 15th day of September, 2009.

ATTEST:

City Clerk

There were no other matters discussed or acted on at this meeting. There being no further business the meeting was adjourned.

; Notary Public

City Council

= \ U \ D \ b [` N c N N \$ 6 W f E R P _ R a N f